

## Pump Model CPS 150-100-310

Speed 2900rpm

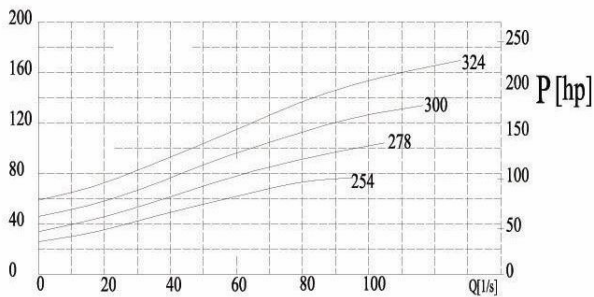

0 50 100 150 200 250 300 350 400 Q[m<sup>3</sup>/h]

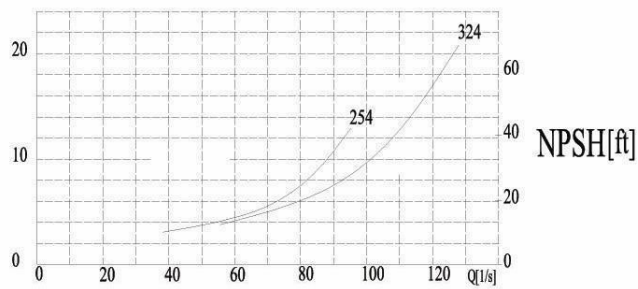
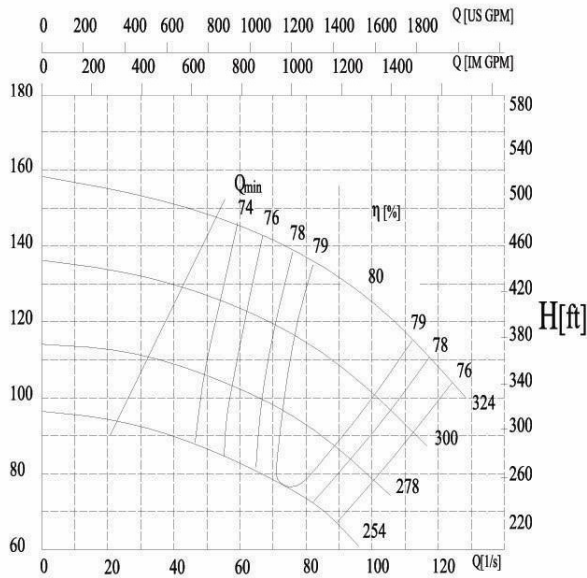
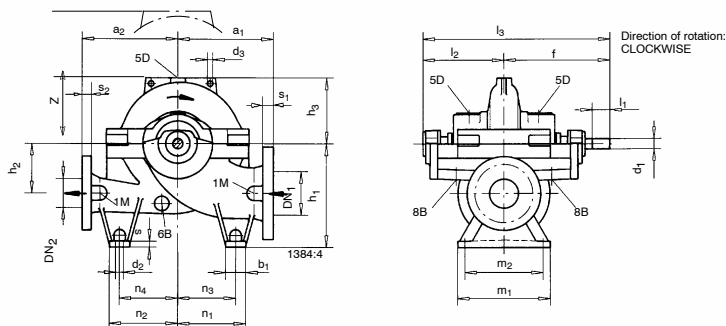

| Pump Size          | FLANGE DIMENSIONS |     |     |     | PUMP DIMENSIONS |       |     |     |     |     |             |      |     |     |
|--------------------|-------------------|-----|-----|-----|-----------------|-------|-----|-----|-----|-----|-------------|------|-----|-----|
|                    | DN1               | DN2 | s1  | s2  | a1              | a2    | d3  | f   | h1  | h2  | h3          | l2   | l3  | z   |
| CPS<br>150-100-310 | 150               | 100 | 37  | 32  | 330             | 330   | 19  | 415 | 355 | 170 | 225         | 300  | 715 | 450 |
|                    | FOOT DIMENSIONS   |     |     |     |                 | SHAFT |     |     |     |     | PUMP WEIGHT |      |     |     |
|                    | b1                | d2  | m1  | m2  | n1              | n2    | n3  | n4  | s   | d1  | L1          | (kg) |     |     |
|                    | 70                | 18  | 320 | 270 | 235             | 235   | 200 | 200 | 20  | 35  | 80          | 225  |     |     |